

IoT endpoint for power metering and sending data via LoRaWAN



Main Characteristics

- Measure up to 3 phases of AC power, RMS voltage, RMS current, power factor, reactive and active power
- Standard DIN case
- Indoor use
- Capable of detecting single and three-phase loads
- Real time readings of consumption in kWh per phase, with internal memory for storing data
- Data transmission via LoRaWAN protocol
- Supports up to 3 CTs, optionally supplied by Khomp, in the following ranges:
 - 25 A with 10 mm diameter
 - 40 A with 16 mm diameter
 - 100 A with 16 mm diameter
 - 150 A with 16 mm diameter
 - 250 A with 24 mm diameter
 - 630 A with 36 mm diameter
 - 1500 A with 50.8 mm diameter

Applications

- Indoor power and energy monitoring for:
 - Healthcare
 - Industry
 - Corporate
 - Agribusiness

Overview

The ITE 11LI Endpoint monitors multiple aspects at multiple power points. Through LoRa radio operation and LoRaWAN protocol, the endpoint sends the observed data to the ITG 200 and the gateway passes the information to the IoT cloud. With this data, the solution is able to analyze key aspects of the load fed to the network, as well as visualize in real time if there are any storms in the supply.

The ITE 11LI also features Bluetooth, allowing firmware updates directly with the device.

Available model and optional accessories

Khomp offers the power measurement endpoint in the following model:

Model	Description
Endpoint LoRa Energy Meter - ITE 11LI	LoRa Endpoint Transmitter with Bluetooth for inductive indoor energy measurement using TCs - ITE 11LI

Accessory (optional)	Description
25A TC PowCT-T10-25-333	25 A TC, 333 mV output, 5 meter cable
40A TC PowCT-T16-40-333	40 A TC, 333 mV output, 2 meter cable
100A TC PowCT-T16-100-333	100 A TC, 333 mV output, 2 meter cable
150A TC PowCT-T16-150-333	150 A TC, 333 mV output, 2 meter cable
250A TC PowCT-T24-250-333	250 A TC, 333 mV output, 2 meter cable
630A TC PowCT-T36-630-333	630 A TC, 333 mV output, 2 meter cable
1500A TC PowCT-T50-1500-333	1500 A TC, 333 mV output, 2 meter cable



Attention

The ITE line can only be used in association with TCs supplied by Khomp. Khomp is not responsible for product problems caused by the use of third-party accessories.

Technical Specifications

Power meter

- Active power: 1% accuracy
- Reactive power: 2% accuracy
- temperature: ± 1 °C
- Power factor:
 - Accuracy: 1%.
 - Accuracy: 0.01
- RMS voltage:
 - Accuracy: 1%
 - Accuracy: 0.1 V
- RMS current:
 - Accuracy: 1%
 - Accuracy: 0,05 A
- Frequency:
 - Accuracy: 1%
 - Accuracy: 0,1 Hz

LoRa

- LoRaWAN Protocol 1.0.3
- Authentication mode: ABP/OTAA
- Região: AU915/LA915/US915/EU868
- LoRaWAN Class: C
- Power: up to +20 dBm
- Sensitivity: from -137 dBm
- Compatible with ATC Public LoRaWAN and Private Networks
- Configurable interval between transmissions (default at 5 min, 1 min for minimum time and 24 h for maximum time)
- Frequency range: 860 to 930 MHz*

Physical/Environmental

- Protective case dimensions standard DIN: 92x77x53 mm
- Weight: 120 g
- Operating temperature: -10 °C to 85 °C
- Operating humidity: 0 to 100% (non-condensing)
- (non-condensed)
- DIN case (ABS rail included)
- Maximum consumption: 1.4 W
- Supply voltage between the Neutral (**N**) and A-phase (**VA**), B-phase (**VB**) or C-phase (**VC**) terminals of the ITE (phase-to-neutral voltages): **90–277 VAC**
- Supply voltage between A-phase (**VA**) and B-phase (**VB**), B-phase (**VB**) and C-phase (**VC**), or A-phase (**VA**) and C-phase (**VC**) (phase-to-phase voltages): **90–478 VAC**
- **Device powered via Neutral (N) and A phase (VA)**

Binary Sensor

- Isolated digital input:
 - ON: 5–24 V
 - OFF: 0 V (zero volt)

Compatible versions

- Gateway Khomp ITG 200 version v2.5.1.0 or better

Warranties and certifications

- Total warranty (legal + Khomp warranty): 1 year
- Anatel certification
- ISO 9001 certified industry

* The 868 MHz band is for sale in the European Union, the 915 MHz band is destined for the USA and Brazil.

Other product images



Caption: In the first part of the image, we see the ITE 11LI in top view, profile view and bottom view. In the central region of the image, we see the connections from the front (with the CT next to it) and the back of the ITE. In the final stage of the image, the side of the product is seen.

Application 1 model

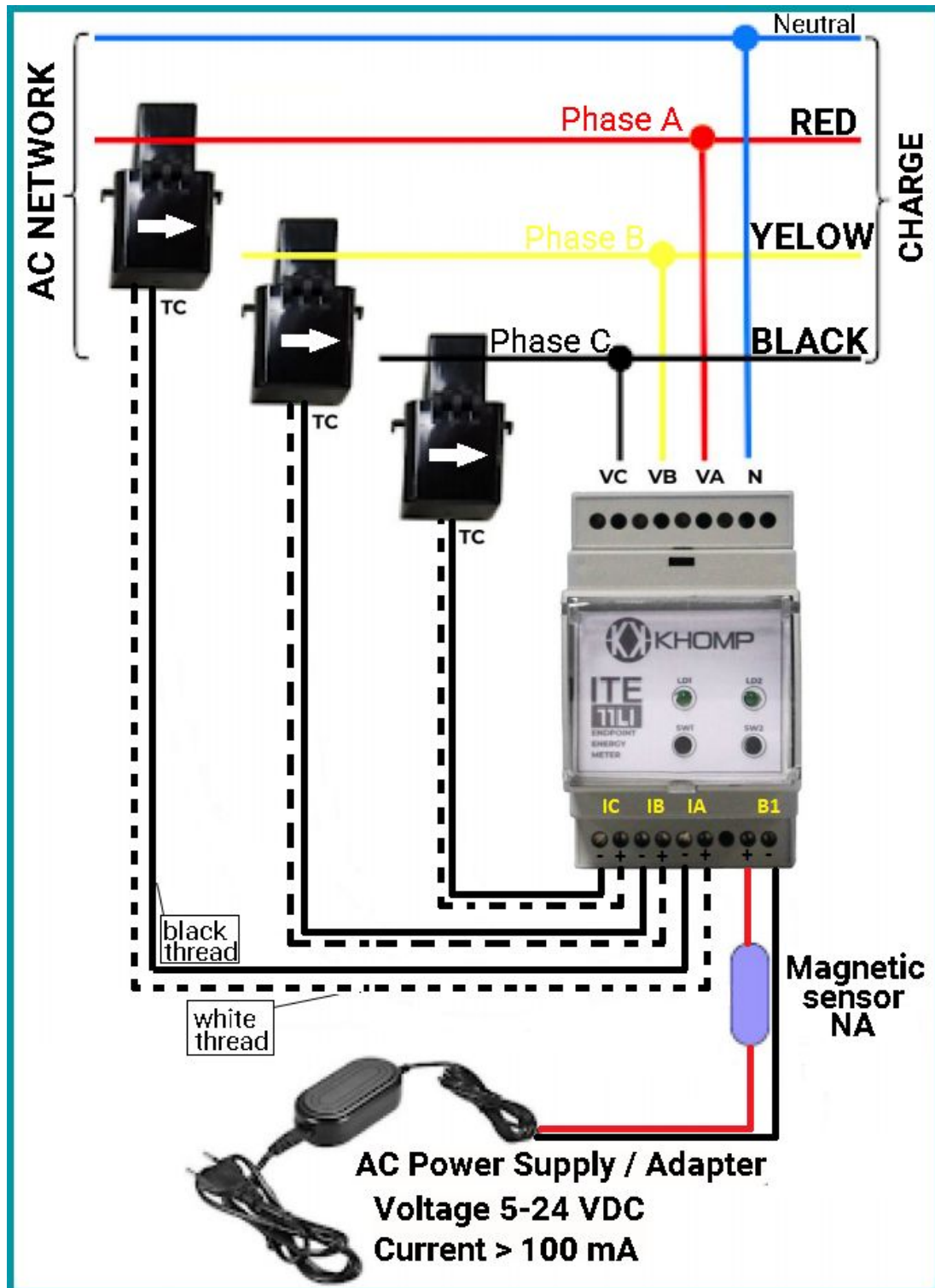

Caption: ITE 11LI monitoring the three-phase load on the main power board.

Application 2 model

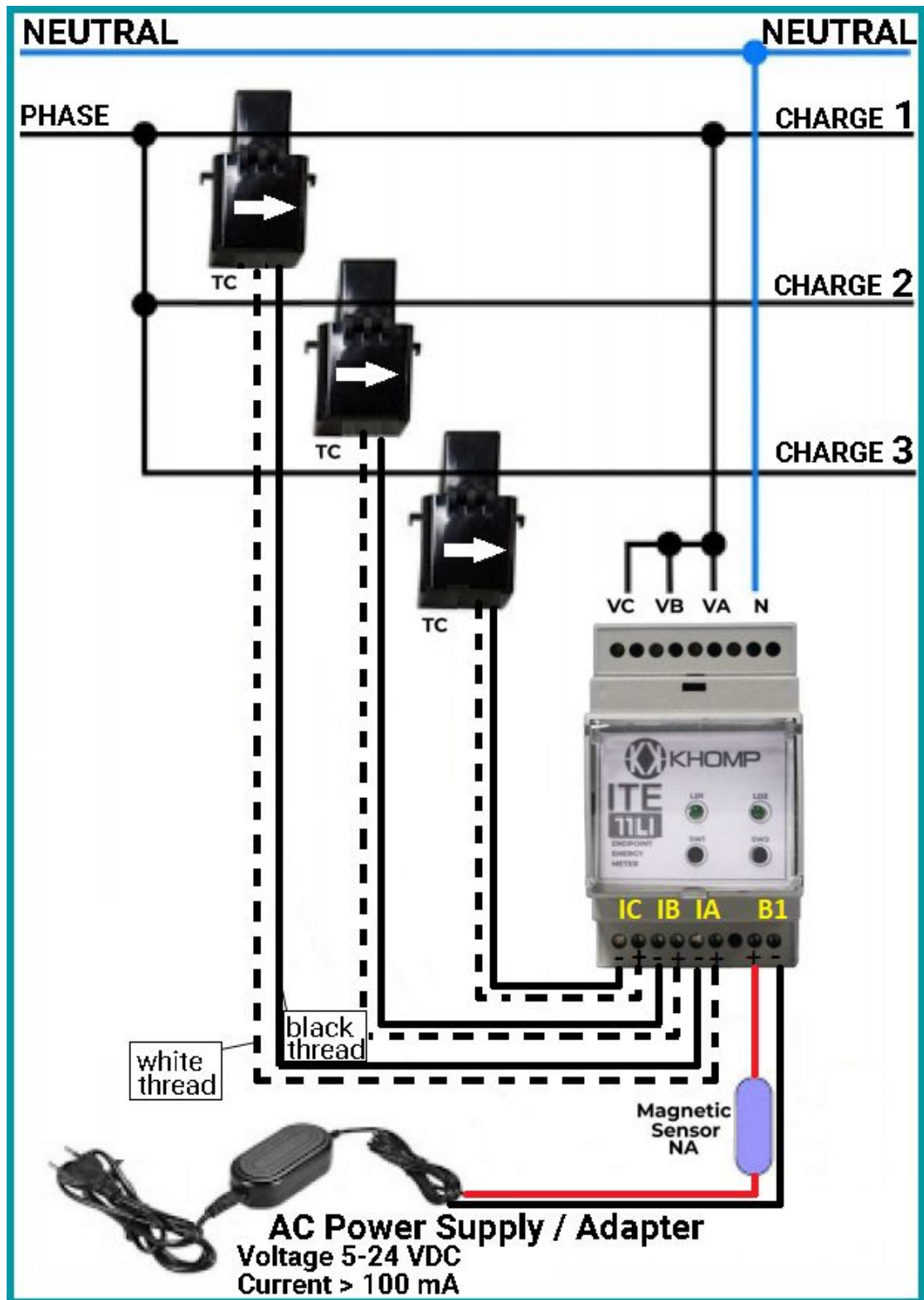

Caption: ITE 11LI monitoring 3 loads on the same phase.

Application 3 model

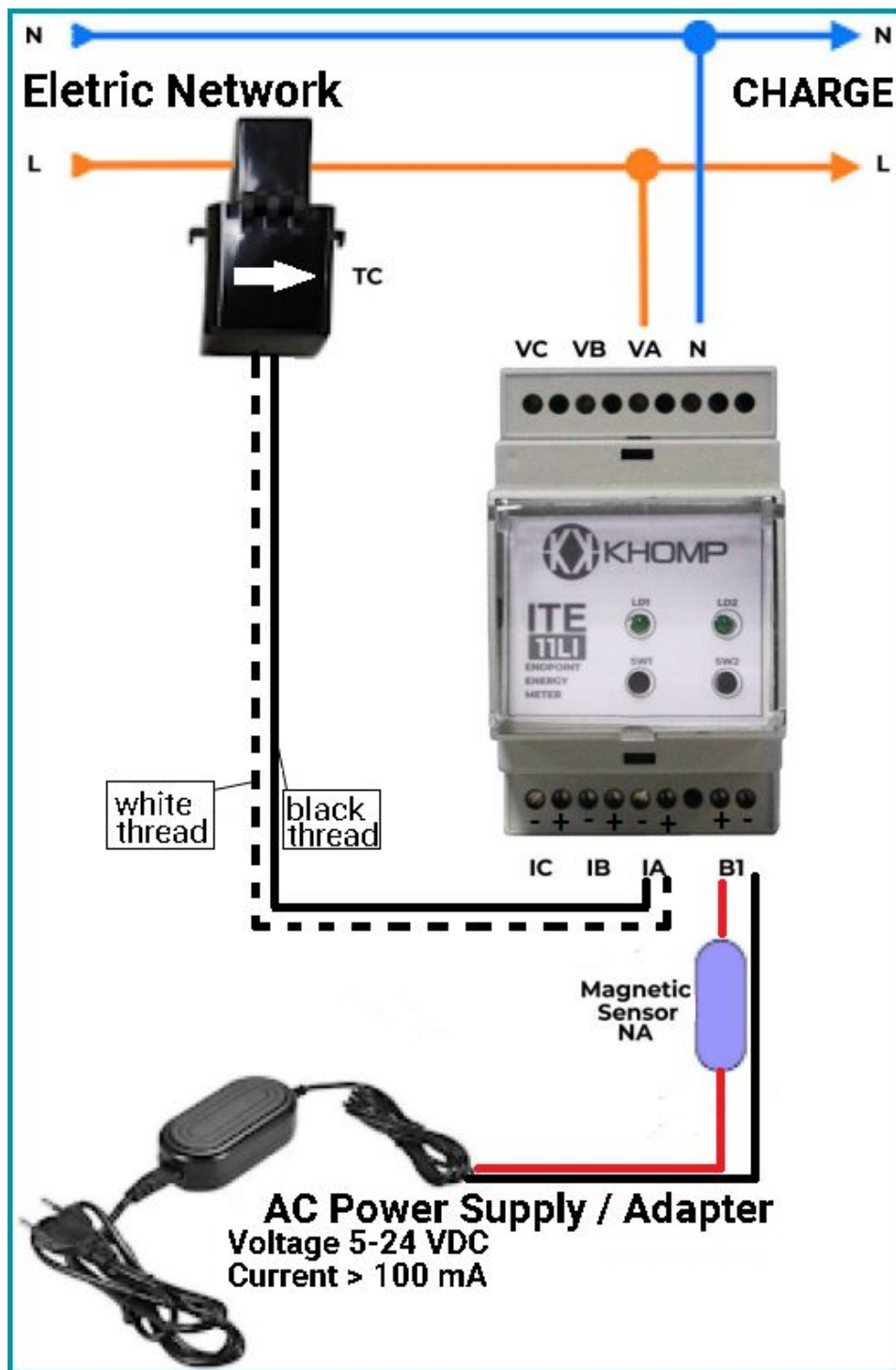

Caption: ITE 11LI monitoring the single-phase load on the datacenter rack, air conditioner, freezer, or electric motor.

Application 4 model

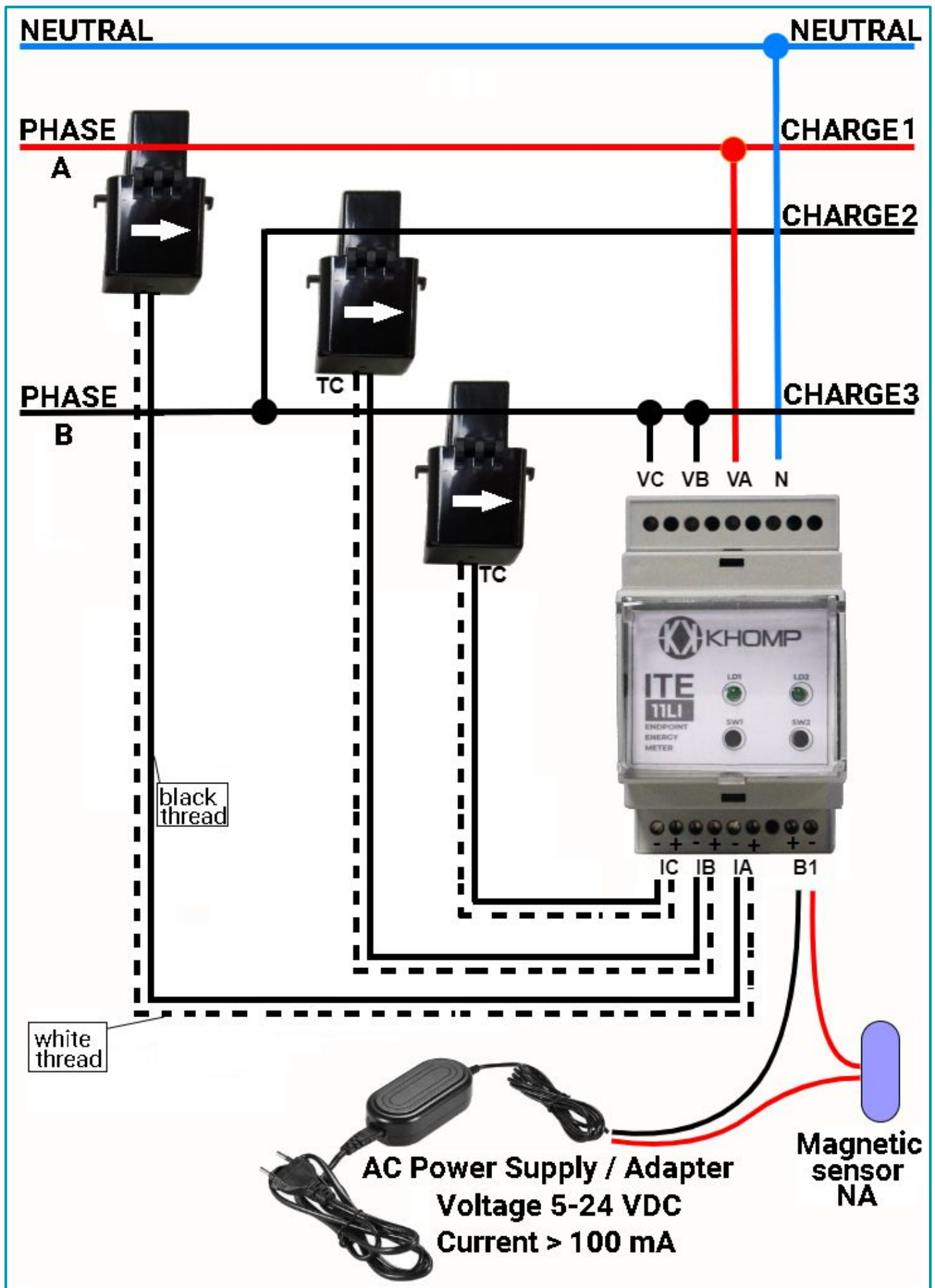

Caption: ITE 11LI monitoring 3 loads in two phases.

Application 5 model

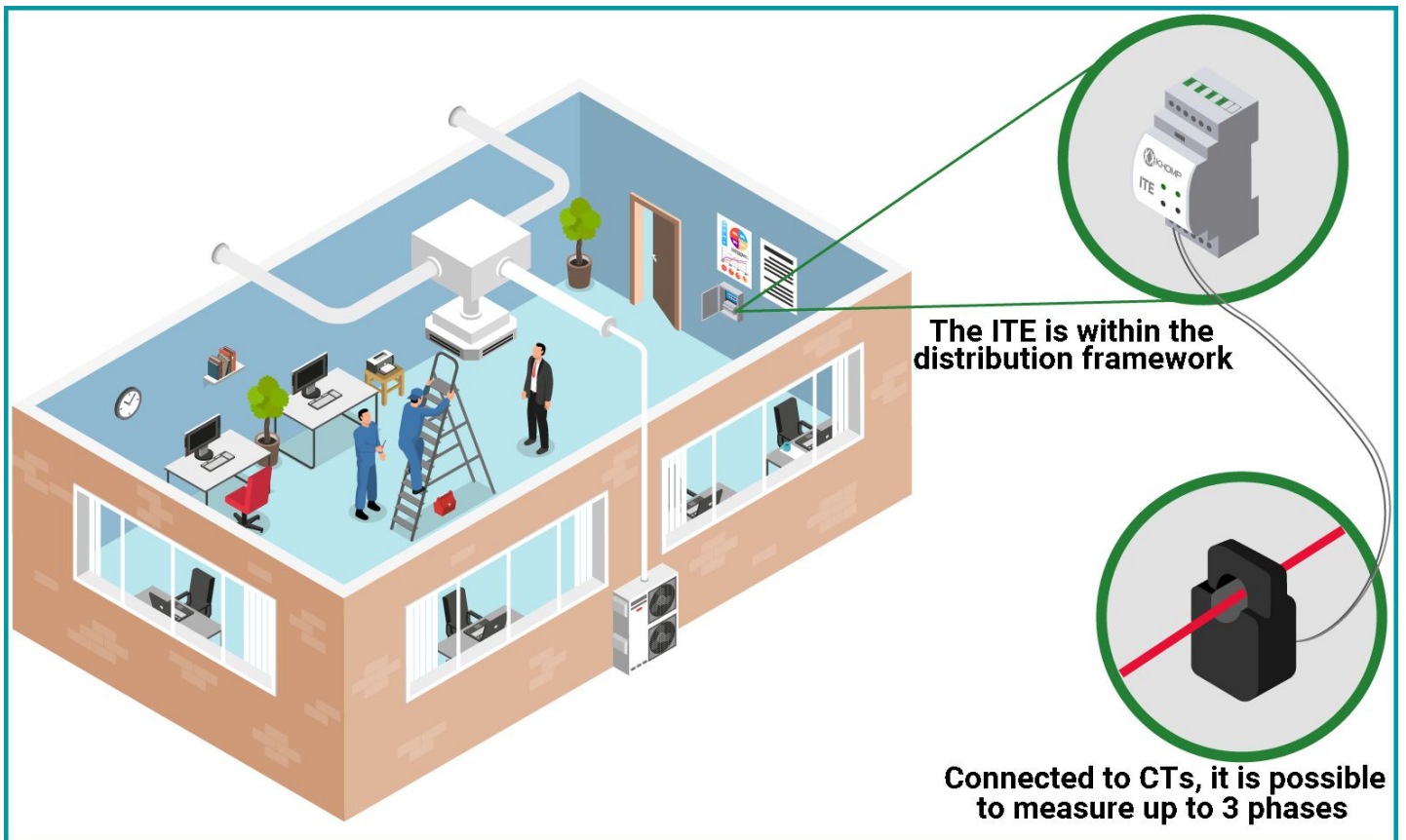

Caption: ITE 10ZI monitoring the three-phase load on the office switchboard.

Everynet interoperability seal

